

HC-49U/S Crystal

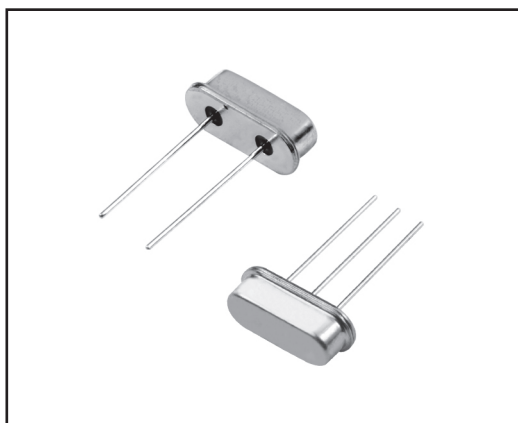

Part Number Guide

T (Type 型号): S=HC - 49S, 2 Leads with height of 3.38mm Max

S2=HC - 49S, 2 Leads with height of 2.8mm Max

S3=HC - 49S, 2 Leads with height of 2.5mm Max

SB=HC - 49S, 3 Leads with height of 3.38mm Max

SB2=HC - 49S, 3 Leads with height of 2.8mm Max

SB3=HC - 49S, 3 Leads with height of 2.5mm Max

M (Mode of Operation 振荡模式) F=Fundamental T=Third Overtone, etc

F (Frequency 标称频率)

LC (Load Capacitance 负载电容): 20=20pf 00=series, etc

FT (Frequency Tolerance 调整频差): 30=+/-30 PPM, etc

FD (Frequency Drift 温度频差): 50=+/-50 PPM, etc

OT (Operating Temperature 工作温度): 1060=-10°C to +60°C 4085=-40°C to +85°C, etc

ESR (Equivalent Series Resistance 等效阻抗)

TR (Tape and Reel 编带)

S (Special Requirement 特殊要求)

Electrical Specifications 电气参数

型号	Holder Type	HC - 49U/S
频率范围	Frequency Range	3.200 to 100.000 MHZ ※(See Notes)
调整频差	Frequency Tolerance (ΔF) (at25°C)	±10ppm to ±100ppm
温度频差	Frequency Drift	±10ppm to ±100ppm
工作温度范围	Operating Temperature Range	-10°C - +60°C to -40°C - +85°C
储存温度范围	Storage Temperature Range	-40°C - +85°C/-55°C - +125°C
老化	Aging (25°C)	±5ppm/ year Maximum
静电容	Shunt Capacitance (C0)	7pF maximum
激励功率	Drive Level	100uW Typical
绝缘阻抗	Insulation Resistance (Rs)	500 Megaohms Minimum at D.C100V
负载电容	Load Capacitance (CL)	Suggested by customer

※Notes: For 2.5mm height, lowest frequency is 10 MHZ.

For 2.8mm height, lowest frequency is 6 MHZ.

Mechanical Dimensions 外型尺寸

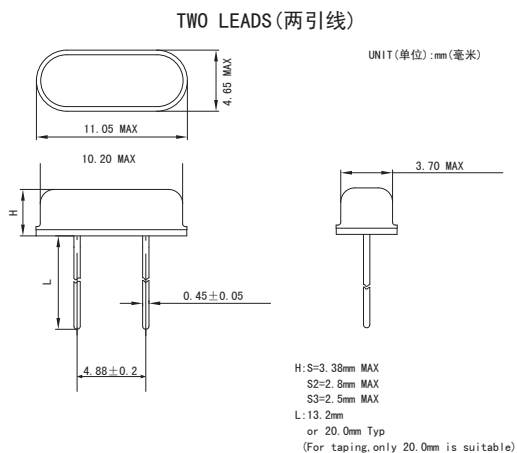

Equivalent Series Resistance and Mode of Operation 等效阻抗和振荡模式

Frequency Range 频率范围	ESR (Ω) 等效阻抗	Mode 振荡模式
3.200 to 3.579 MHZ	250Max	基频 Fundamental
3.580 to 3.999 MHZ	150Max	Fundamental
4.000 to 4.999 MHZ	120Max	Fundamental
5.000 to 5.999 MHZ	100Max	Fundamental
6.000 to 6.999 MHZ	80Max	Fundamental
7.000 to 9.999 MHZ	60Max	Fundamental
10.000 to 13.999 MHZ	50Max	Fundamental
14.000 to 19.999 MHZ	40Max	Fundamental
≥20.000 MHZ	30/40 (BT cut) Max	Fundamental
24.000 to 34.999 MHZ	100Max	三次泛音 Third Overtone
≥35.000 MHZ	80Max	Third Overtone

