

# Low Phase Noise Crystal Oscillator



2CN / 3CN / 5CN / 7CN

## Feature

- Ceramic surface mount with Metal Lid
- CMOS compatible logic levels
- Tri-state function available
- RMS Phase Jitter: 0.3pSec max.
- RoHS Compliant / Pb Free

## Applications

- Wireless Devices
- Internet of Things (IoT) devices
- Fibre Channel
- Ethernet/Gigabit Ethernet
- Portable Electronics

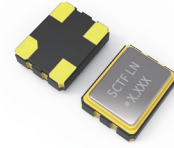

## Electrical Specifications

Item	Symb.	Min.	Typ.	Max.	Unit	Notes
Frequency Range	Freq.	1	—	54	MHz	
Operating Temperature	T <sub>use</sub>	-40	—	+85	°C	
Storage Temperature Range	T <sub>stg</sub>	-55	—	+155	°C	
Supply Voltage	V <sub>dd</sub>	2.97	3.3	3.63	V	
		2.25	2.5	2.75	V	
		1.62	1.8	1.98	V	
Output Load(CMOS)	L <sub>CMOS</sub>	15			pF	
Current Consumption	I <sub>cc</sub>	—	—	10	mA	1MHz ≤ Freq. < 40MHz, L <sub>CMOS</sub> = 15pF
		—	—	20		40MHz ≤ Freq. ≤ 54MHz, L <sub>CMOS</sub> = 15pF
Duty Cycle	SYM	45	—	55	%	50% V <sub>dd</sub> level, L <sub>CMOS</sub> ≤ 15pF
Output Voltage	V <sub>OH</sub>	0.9V <sub>dd</sub>	—	—	V	
	V <sub>OL</sub>	—	—	0.1V <sub>dd</sub>		
Enable Voltage High	V <sub>IH</sub>	0.7V <sub>dd</sub>	—	—	V	Output will be disable if OE is Logic"0" Output will be enable if OE is Logic"1" or open
Disable Voltage Low	V <sub>IL</sub>	—	—	0.3V <sub>dd</sub>		
Rise / Fall Time	T <sub>R</sub> / T <sub>F</sub>	—	—	5	nS	10% V <sub>dd</sub> to 90% V <sub>dd</sub> level
Start-up time	T <sub>str</sub>	—	—	5	mS	To 90% of Final Amplitude
RMS Phase Jitter	PJ	Please see Table2 below				Offset: 12kHz to 20MHz
Aging	f <sub>age</sub>	-3	—	+3	ppm	at 25°C ± 3°C. First Year

## Electrical Specifications Cont.

• Table 1: Frequency Stability VS. Temperature

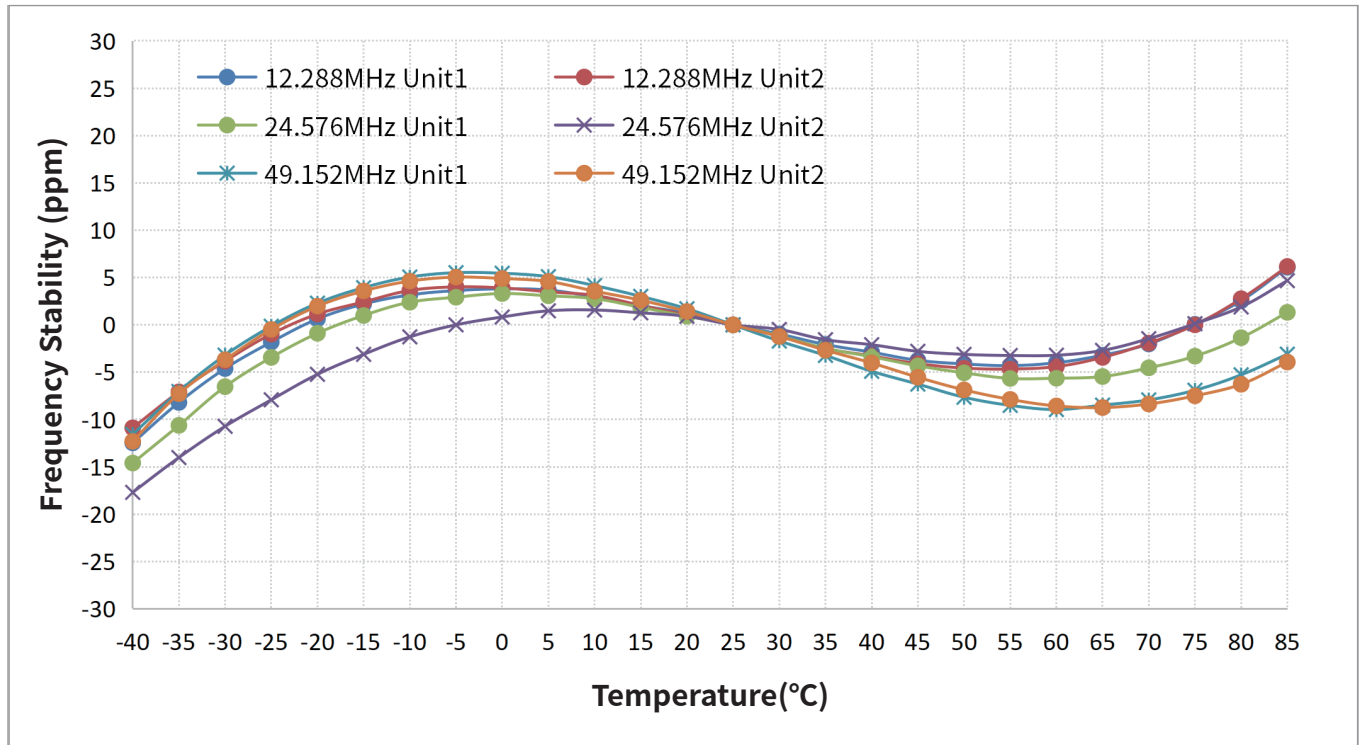

• Table 2: RMS Phase Jitter (Offset: 12kHz to 20MHz)

Frequency	RMS Jitter (Typical)
	Supply Voltage = 3.3V
11.2896MHz	160.25fs
12.288MHz	146.663fs
16.384MHz	120.679fs
22.5792MHz	90.242fs
24.576MHz	81.092fs
25.000MHz	80.103fs
32.768MHz	64.72fs
40.000MHz	111.645fs
45.1584MHz	107.365fs
49.152MHz	111.575fs
50.000MHz	104.544fs

# Low Phase Noise Crystal Oscillator



2CN / 3CN / 5CN / 7CN

Frequency: 11.2896MHz Vdd=3.3V

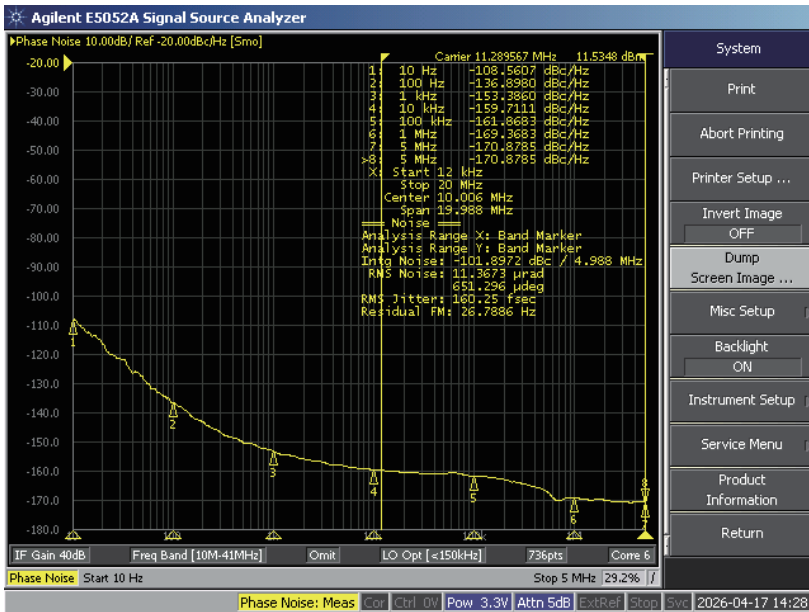

Table 3: Phase Noise Plots (Unit: dBc/Hz)

Frequency (11.2896MHz)	
Frequency	Supply Voltage (3.3V)
10Hz	-108.5607
100Hz	-136.8980
1kHz	-153.3860
10kHz	-159.7111
100kHz	-161.8683
1MHz	-169.3683
5MHz	-170.8785

Frequency: 12.288MHz Vdd=3.3V

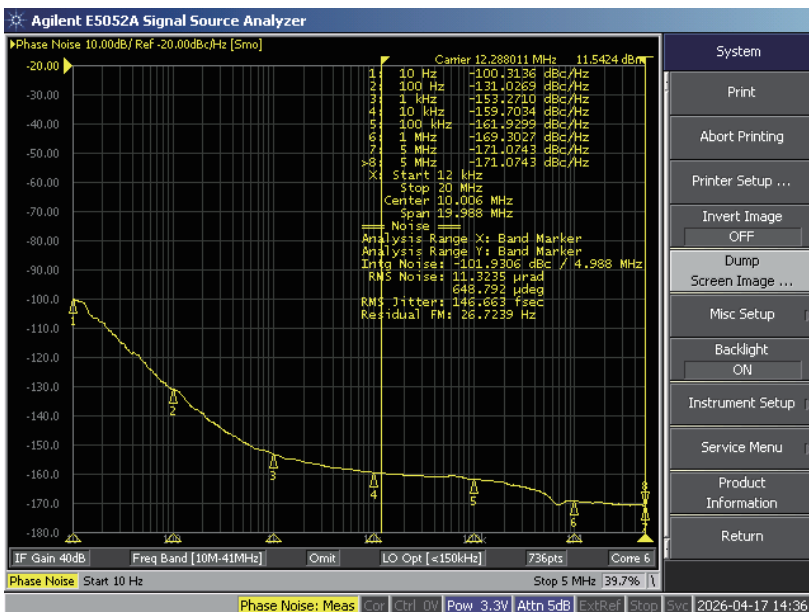

Table 3: Phase Noise Plots (Unit: dBc/Hz)

Frequency (12.288MHz)	
Frequency	Supply Voltage (3.3V)
10Hz	-100.3136
100Hz	-131.0269
1kHz	-153.2710
10kHz	-159.7034
100kHz	-161.9299
1MHz	-169.3027
5MHz	-171.0743

# Low Phase Noise Crystal Oscillator



2CN / 3CN / 5CN / 7CN

Frequency: 16.384MHz Vdd=3.3V

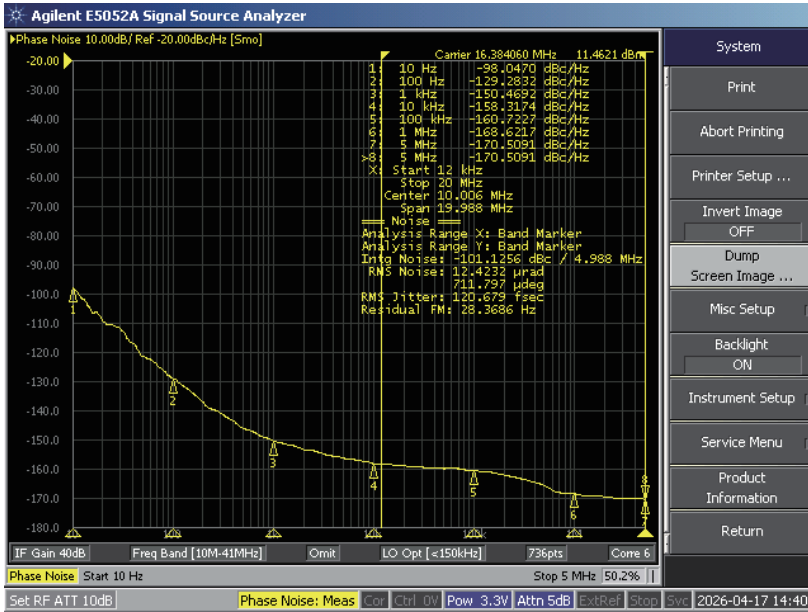

Table 3: Phase Noise Plots (Unit: dBc/Hz)

Frequency (16.384MHz)	
Frequency	Supply Voltage (3.3V)
10Hz	-98.0470
100Hz	-129.2832
1kHz	-150.4692
10kHz	-158.3174
100kHz	-160.7227
1MHz	-168.6217
5MHz	-170.5091

Frequency: 22.5792MHz Vdd=3.3V

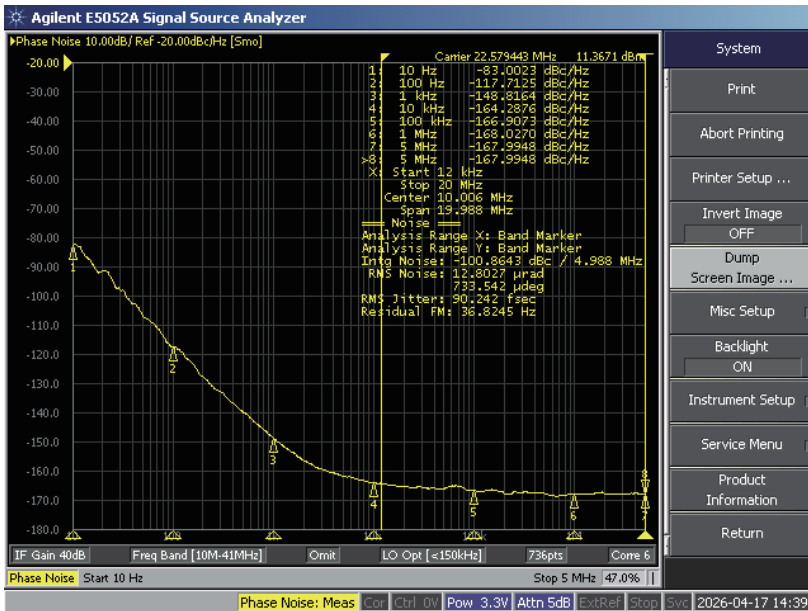

Table 3: Phase Noise Plots (Unit: dBc/Hz)

Frequency (22.5792MHz)	
Frequency	Supply Voltage (3.3V)
10Hz	-83.0023
100Hz	-117.7125
1kHz	-148.8164
10kHz	-164.2876
100kHz	-166.9073
1MHz	-168.0270
5MHz	-167.9948

# Low Phase Noise Crystal Oscillator



2CN / 3CN / 5CN / 7CN

Frequency: 24.576MHz Vdd=3.3V

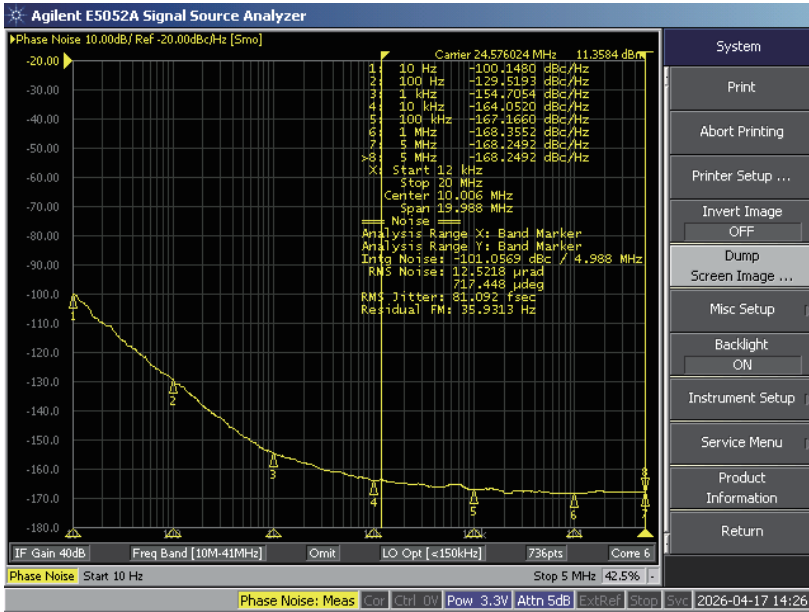

Table 3: Phase Noise Plots (Unit: dBc/Hz)

Frequency (24.576MHz)	
Frequency	Supply Voltage (3.3V)
10Hz	-100.1480
100Hz	-129.5193
1kHz	-154.7054
10kHz	-164.0520
100kHz	-167.1660
1MHz	-168.3552
5MHz	-168.2492

Frequency: 25.000MHz Vdd=3.3V

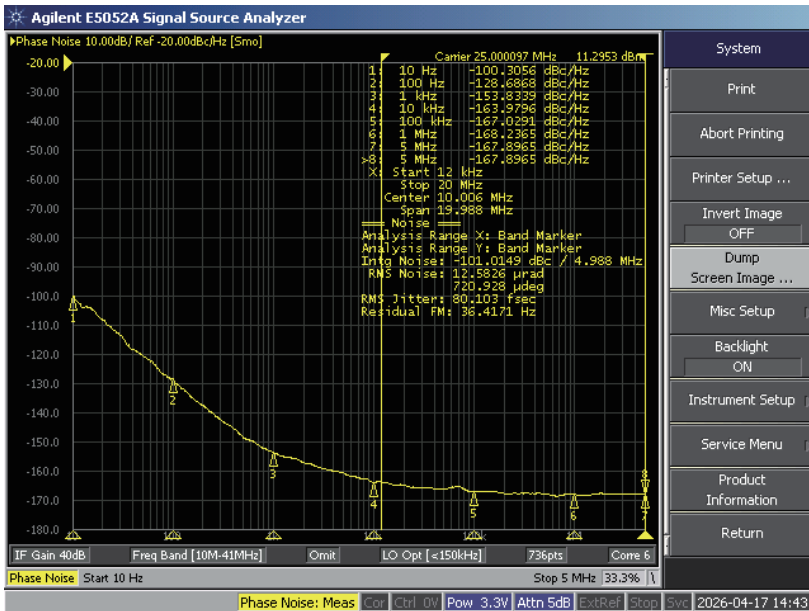

Table 3: Phase Noise Plots (Unit: dBc/Hz)

Frequency (25.000MHz)	
Frequency	Supply Voltage (3.3V)
10Hz	-100.3056
100Hz	-128.6868
1kHz	-153.8339
10kHz	-163.9796
100kHz	-167.0291
1MHz	-168.2365
5MHz	-167.8965

# Low Phase Noise Crystal Oscillator



2CN / 3CN / 5CN / 7CN

Frequency: 32.768MHz Vdd=3.3V

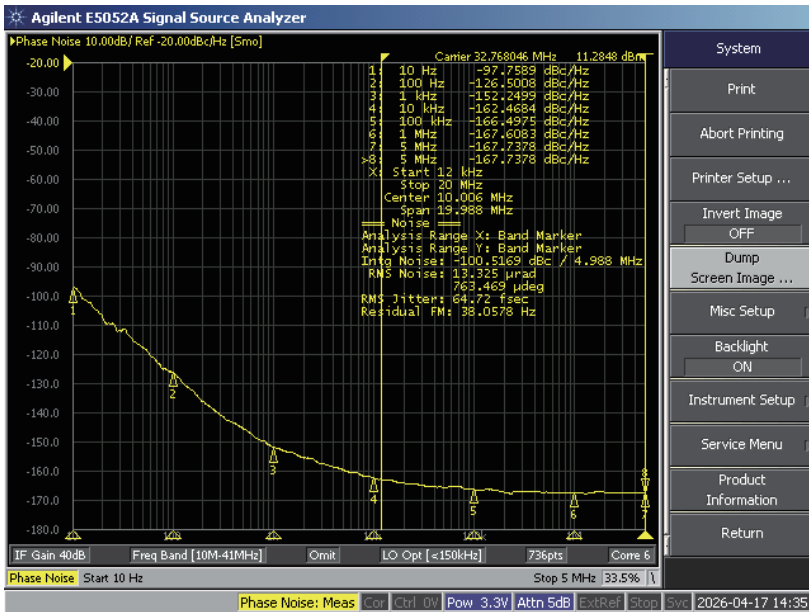

Table 3: Phase Noise Plots (Unit: dBc/Hz)

Frequency (32.768MHz)	
Frequency	Supply Voltage (3.3V)
10Hz	-97.7589
100Hz	-126.5008
1kHz	-152.2499
10kHz	-162.4684
100kHz	-166.4975
1MHz	-167.6083
5MHz	-167.7378

Frequency: 40.000MHz Vdd=3.3V

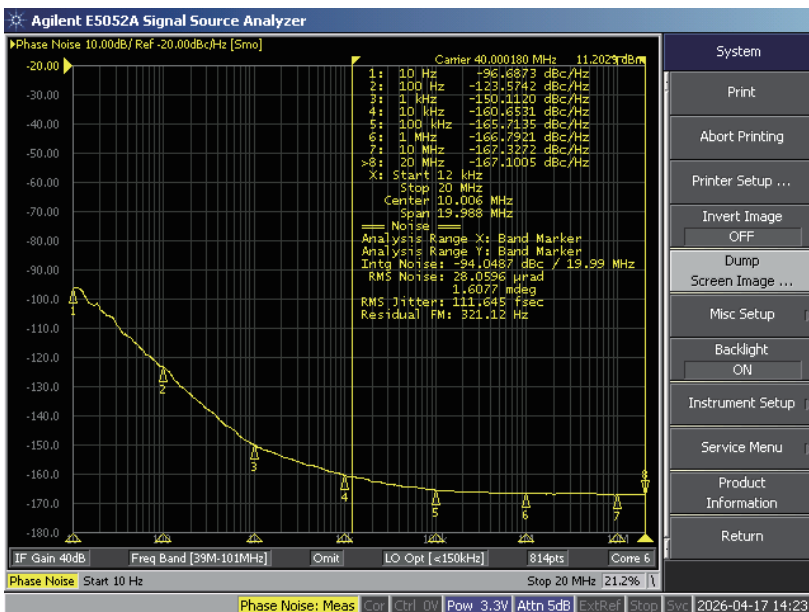

Table 3: Phase Noise Plots (Unit: dBc/Hz)

Frequency (40.000MHz)	
Frequency	Supply Voltage (3.3V)
10Hz	-96.6873
100Hz	-123.5742
1kHz	-150.1120
10kHz	-160.6531
100kHz	-165.7135
1MHz	-166.7921
10MHz	-167.3272
20MHz	-167.1005

# Low Phase Noise Crystal Oscillator



2CN / 3CN / 5CN / 7CN

Frequency: 45.1584MHz Vdd=3.3V

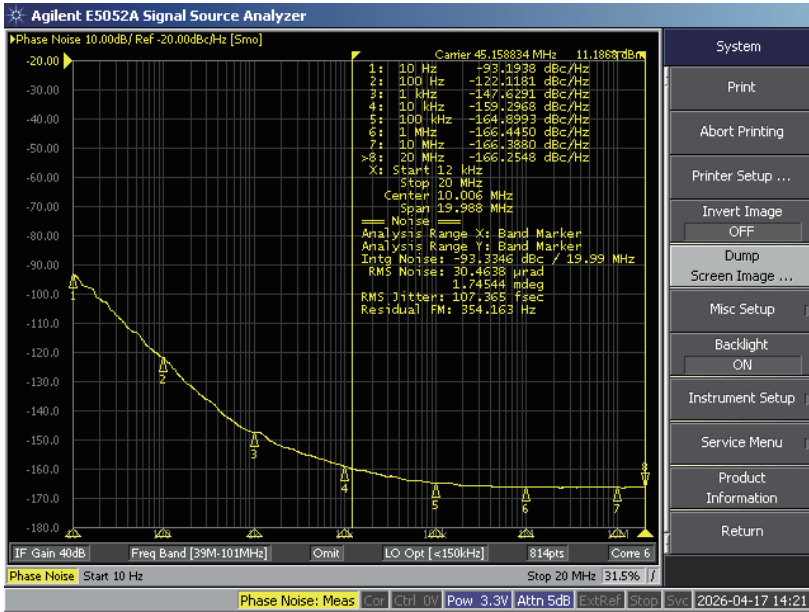

Table 3: Phase Noise Plots (Unit: dBc/Hz)

Frequency (45.1584MHz)	
Frequency	Supply Voltage (3.3V)
10Hz	-93.1938
100Hz	-122.1181
1kHz	-147.6291
10kHz	-159.2968
100kHz	-164.8993
1MHz	-166.4450
10MHz	-166.3880
20MHz	-166.2548

Frequency: 49.152MHz Vdd=3.3V

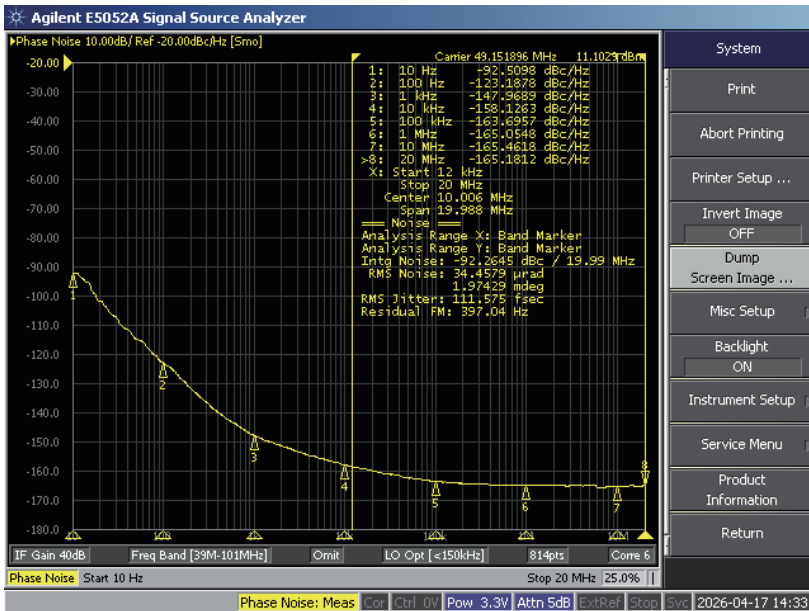

Table 3: Phase Noise Plots (Unit: dBc/Hz)

Frequency (49.152MHz)	
Frequency	Supply Voltage (3.3V)
10Hz	-92.5098
100Hz	-123.1878
1kHz	-147.9689
10kHz	-158.1263
100kHz	-163.6957
1MHz	-165.0548
10MHz	-165.4618
20MHz	-165.1812

# Low Phase Noise Crystal Oscillator



2CN / 3CN / 5CN / 7CN

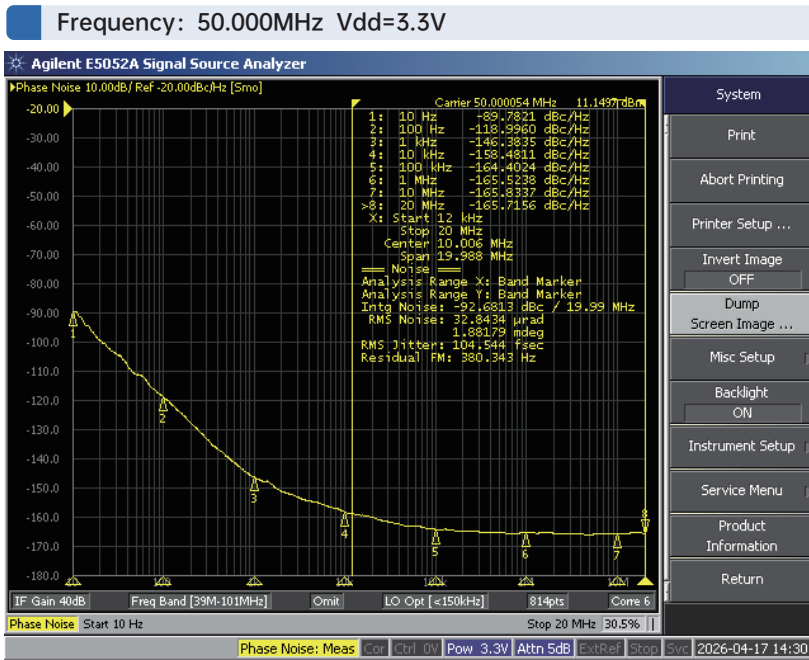

Table 3: Phase Noise Plots (Unit: dBc/Hz)

Frequency (50.000MHz)	
Frequency	Supply Voltage (3.3V)
10Hz	-89.7821
100Hz	-118.9960
1kHz	-146.3835
10kHz	-158.4811
100kHz	-164.4024
1MHz	-165.5238
10MHz	-165.8337
20MHz	-165.7156

# Low Phase Noise Crystal Oscillator



2CN / 3CN / 5CN / 7CN

## Dimensions (UNIT:mm)

## Solder pad layout (UNIT:mm)

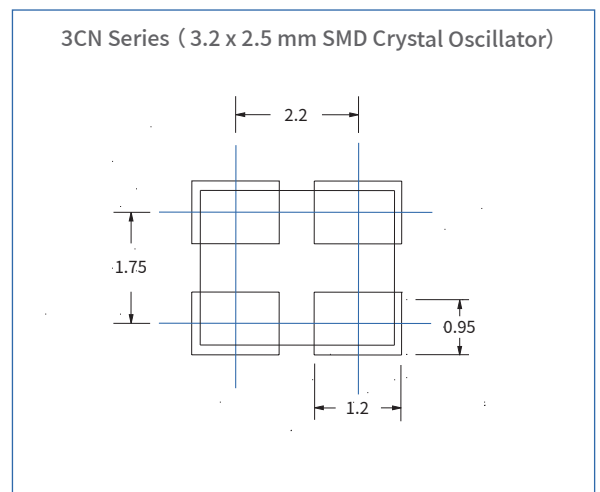
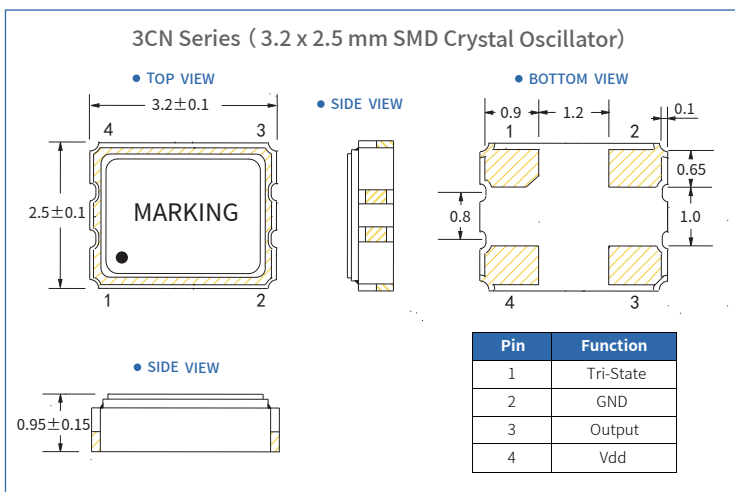
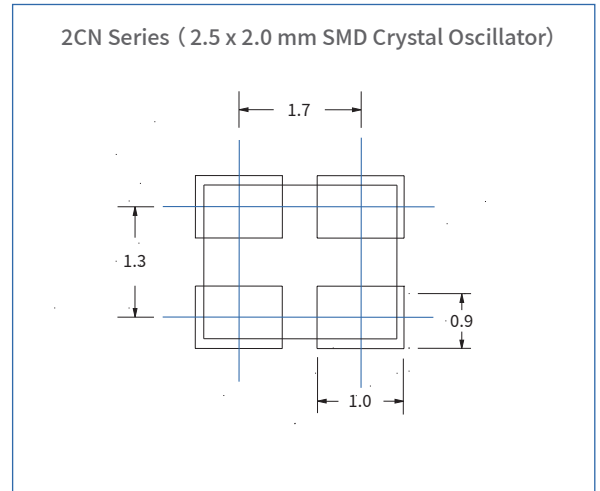
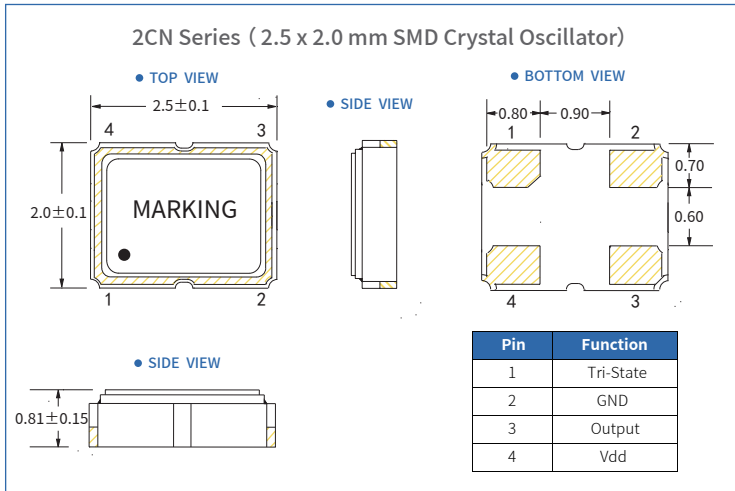

# Low Phase Noise Crystal Oscillator



2CN / 3CN / 5CN / 7CN

## Dimensions (UNIT:mm)

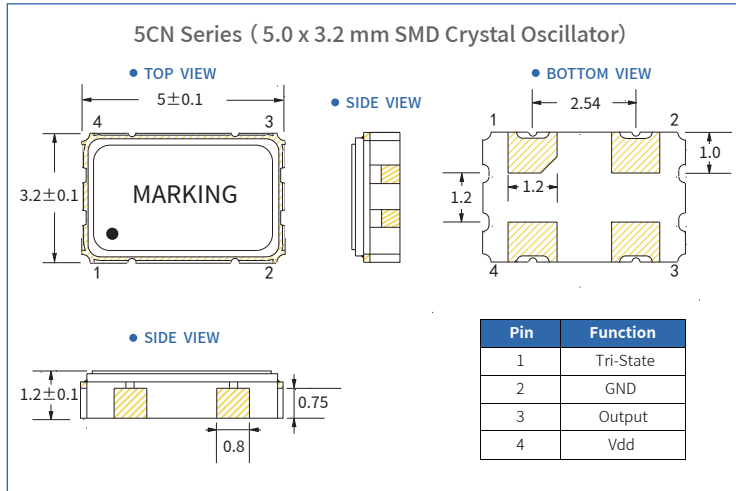

## Solder pad layout (UNIT:mm)

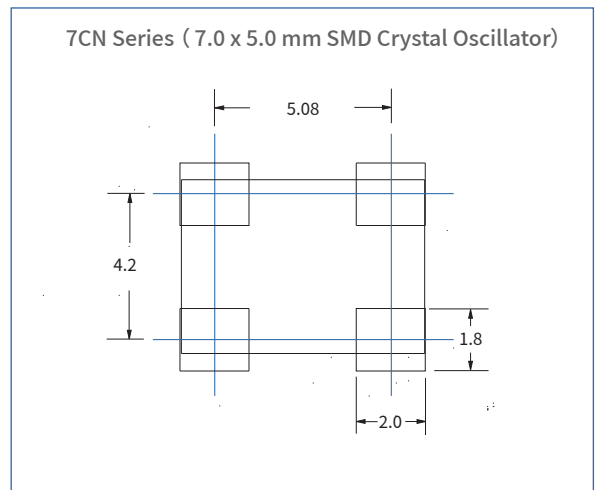
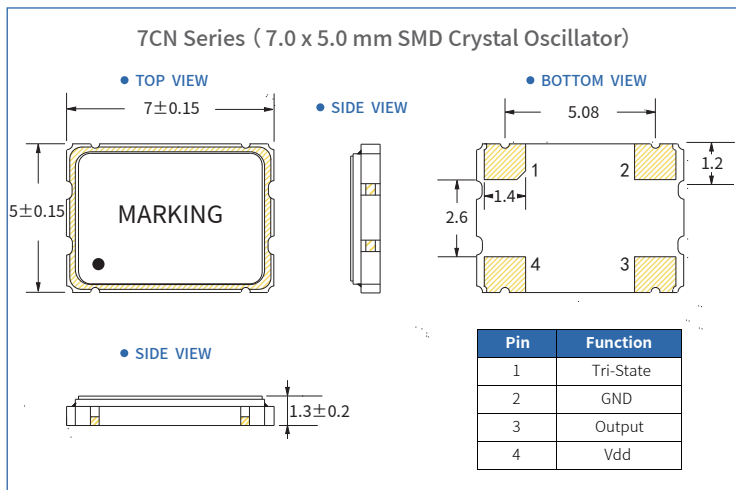
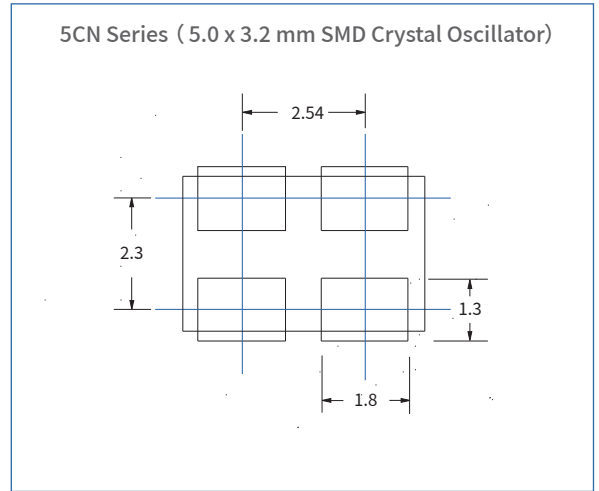

# Low Phase Noise Crystal Oscillator



2CN / 3CN / 5CN / 7CN

## Options and Part Identification

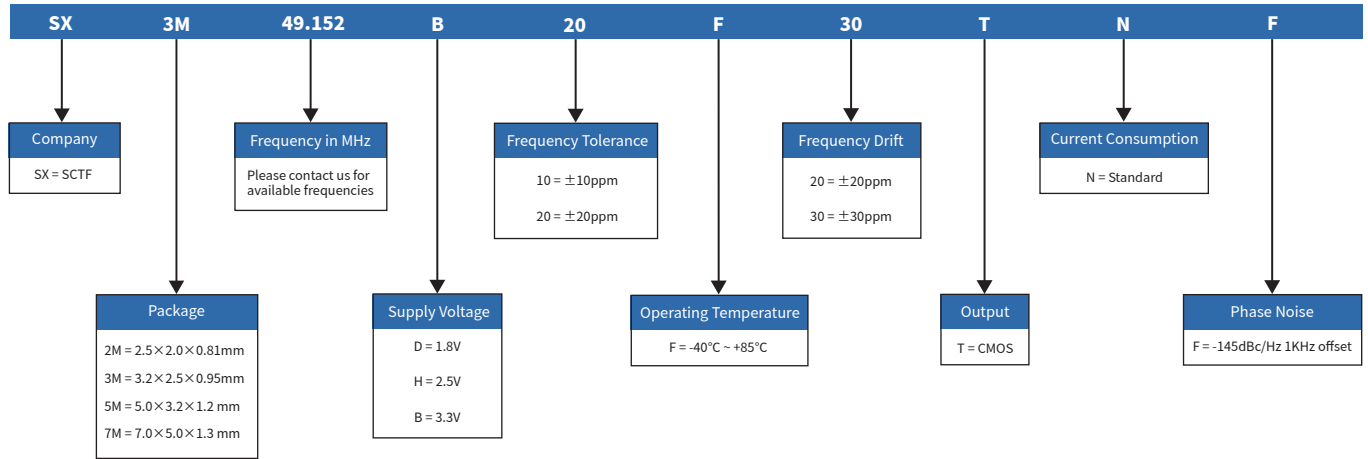

## List of available part numbers

Part NO#			
SX2M11.2896B20F30TNF	SX3M11.2896B20F30TNF	SX5M11.2896B20F30TNF	SX7M11.2896B20F30TNF
SX2M12.288B20F30TNF	SX3M12.288B20F30TNF	SX5M12.288B20F30TNF	SX7M12.288B20F30TNF
SX2M16.384B20F30TNF	SX3M16.384B20F30TNF	SX5M16.384B20F30TNF	SX7M16.384B20F30TNF
SX2M22.5792B20F30TNF	SX3M22.5792B20F30TNF	SX5M22.5792B20F30TNF	SX7M22.5792B20F30TNF
SX2M24.576B20F30TNF	SX3M24.576B20F30TNF	SX5M24.576B20F30TNF	SX7M24.576B20F30TNF
SX2M25.000B20F30TNF	SX3M25.000B20F30TNF	SX5M25.000B20F30TNF	SX7M25.000B20F30TNF
SX2M32.768B20F30TNF	SX3M32.768B20F30TNF	SX5M32.768B20F30TNF	SX7M32.768B20F30TNF
SX2M40.000B20F30TNF	SX3M40.000B20F30TNF	SX5M40.000B20F30TNF	SX7M40.000B20F30TNF
SX2M45.1584B20F30TNF	SX3M45.1584B20F30TNF	SX5M45.1584B20F30TNF	SX7M45.1584B20F30TNF
SX2M50.000B20F30TNF	SX3M50.000B20F30TNF	SX5M50.000B20F30TNF	SX7M50.000B20F30TNF

## Reflow Profile

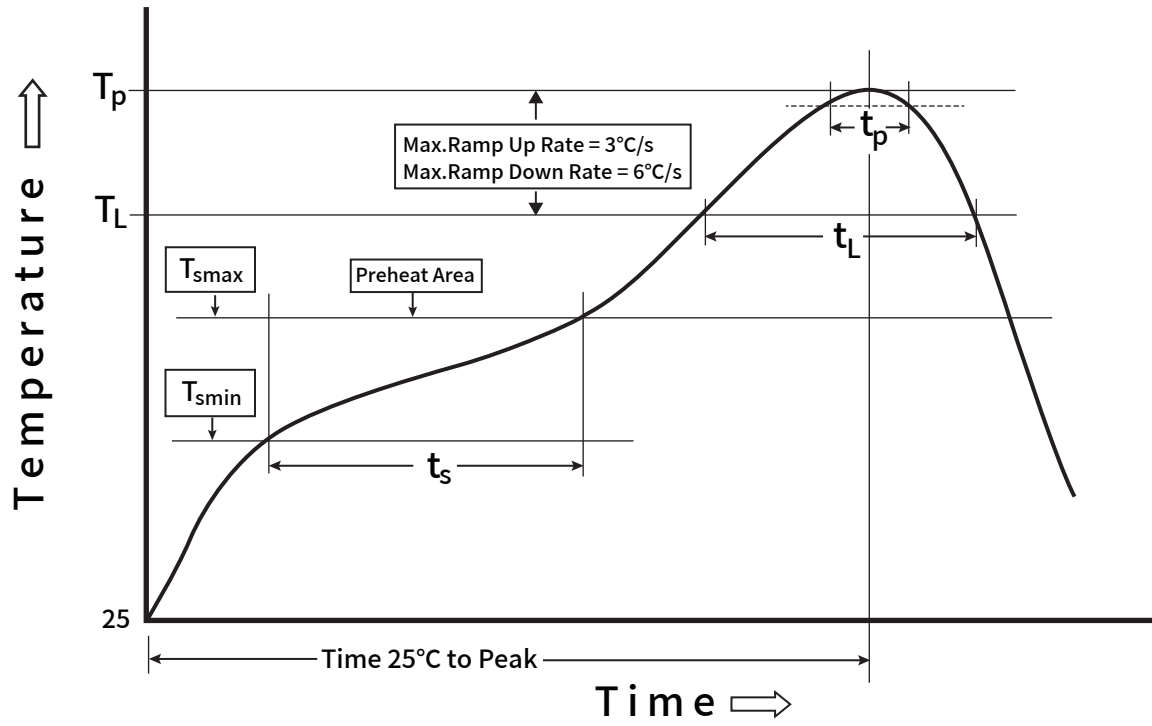

Profile Feature	Sn - Pb Eutectic Assembly	Preheat / Soak
Preheat / Soak ● Temperature Min ( T <sub>s</sub> min ) ● Temperature Max ( T <sub>s</sub> max ) ● Time ( T <sub>s</sub> min to T <sub>s</sub> max )	100°C 150°C 60-120 seconds	150°C 200°C 60-120 seconds
Ramp - up rate ( T <sub>L</sub> to T <sub>p</sub> )	3°C/ second max.	3°C/ second max.
Time maintained above ● Liquidous temperature ( T <sub>L</sub> ) ● Time ( t <sub>L</sub> ) maintained above T <sub>L</sub>	183°C 60-150 seconds	217°C 60-150 seconds
Peak package body temperature ( T <sub>p</sub> )	235°C	260°C
Time within 5° C of the specified classification temperature ( T <sub>p</sub> )	20 seconds	30 seconds
Ramp - down rate ( T <sub>p</sub> to T <sub>L</sub> )	6°C/ second max.	6°C/ second max.
Time 25° C to peak temperature	6 minutes max.	8 minutes max.
<b>Suggust reflow times</b>	<b>2 Times max.</b>	

# Low Phase Noise Crystal Oscillator



■ 2CN / 3CN / 5CN / 7CN

## Testing Circuit

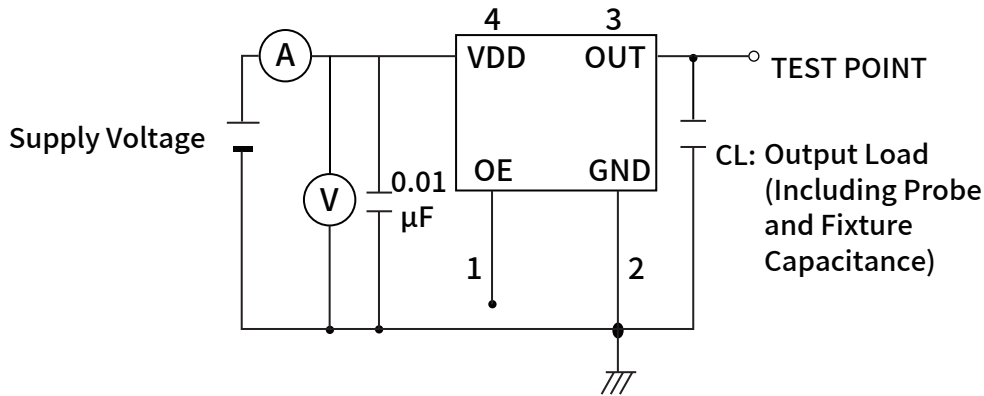

Notes: PIN 1 connected to Vdd or floating, the product is working properly; connected to GND, stops working.

## Waveform Conditions

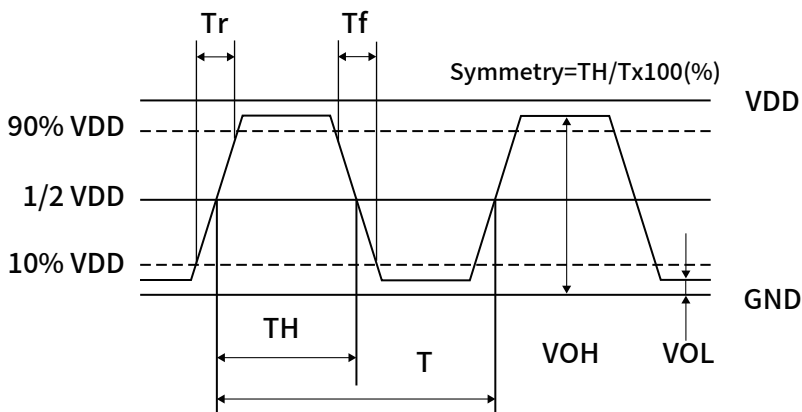

Waveform measurement system should have a min. bandwidth of 5 times the frequency being tested.

# Low Phase Noise Crystal Oscillator



■ 2CN / 3CN / 5CN / 7CN

## Reliability Specification

NO.	Item	Conditions	Basis of Verdict
1	Drop	High:100cm;Thickness:3cm;3 times.	$\Delta FL \leq \pm 5 \text{ppm}$
2	Vibration	Frequency:10~500HZ speed:11min/cycle Amplitude:1.5mm(10~55Hz) acceleration rate:200m/s <sup>2</sup> (55~500Hz) Direction:X,Y,Z	$\Delta FL \leq \pm 5 \text{ppm}$
3	Low Temperature Storage	Temp:-40°C±2°C;Times:96h	$\Delta FL \leq \pm 5 \text{ppm}$
4	High Temperature Storage	Temp:125°C±2°C;Times:96h	$\Delta FL \leq \pm 5 \text{ppm}$
5	High Temp.&Humidity	Temp:80°C±2°C; Humidity:85%±5%;Times:1000h	$\Delta FL \leq \pm 5 \text{ppm}$
6	Thermal Shock	-40°C±2°C (30min) ↔ 85°C±2°C (30min) ; For 100 cycles	$\Delta FL \leq \pm 5 \text{ppm}$
7	Resistance to Soldering Heat	Keep 150 °C ± 5 °C 120s and then rose to 265 °C ± 5 °C for 10s,warming and holding time is less than the 200s, placed at room temperature 1 ~ 2h after test	$\Delta FL \leq \pm 5 \text{ppm}$
8	Aging	Temp:85°C;Times:30days	$\Delta FL \leq \pm 5 \text{ppm}$
9	Soldering Test	Dipping in solder bath at 245deg.C ± 5deg.C for 3±0.5 sec.	Soldering tin rate greater than 95%

# Low Phase Noise Crystal Oscillator



■ 2CN / 3CN / 5CN / 7CN

## Taping Specifications

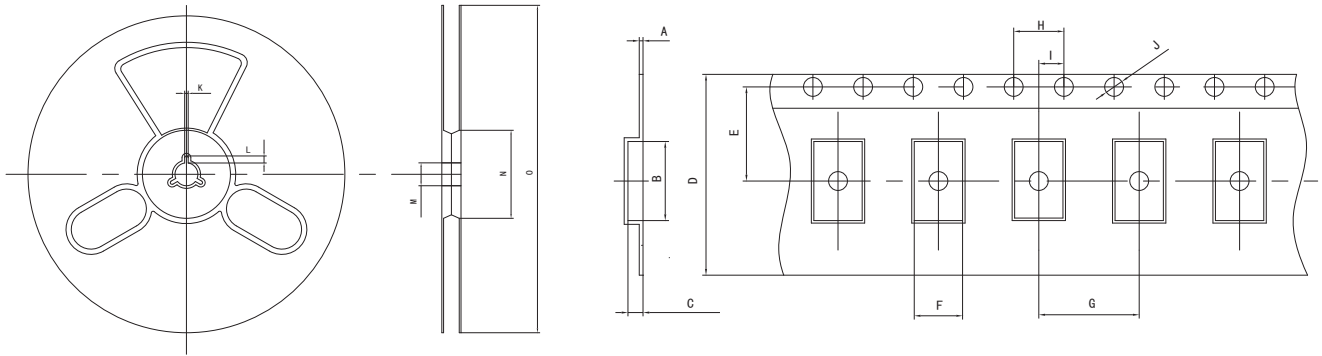

## Pocket Tape Dimensions(mm)

Series	A	B	C	D	E	F	G	H	I	J	K	L	M	N	O
2CN	0.25±0.05	3.5±0.1	1.4±0.1	8.0±0.1	3.5±0.1	2.70±0.1	4.0±0.1	4.0±0.1	2.0±0.1	φ1.5±0.1	2.0±0.2	4.0±1.0	φ13±0.5	φ60±1	φ180±1
3CN	0.25±0.05	3.5±0.1	1.4±0.1	8.0±0.1	3.5±0.1	2.70±0.1	4.0±0.1	4.0±0.1	2.0±0.1	φ1.5±0.1	2.0±0.2	4.0±1.0	φ13±0.5	φ60±1	φ180±1
5CN	0.3±0.05	5.5±0.1	1.25±0.1	12±0.1	5.5±0.1	3.6±0.1	8.0±0.1	4.0±0.1	2.0±0.1	φ1.5±0.1	2.0±0.2	4.0±1.0	φ13±0.5	φ60±1	φ180±1
7CN	0.3±0.05	7.6±0.1	2.0±0.1	16±0.3	7.5±0.1	5.4±0.1	8.0±0.1	4.0±0.1	2.0±0.1	φ1.5±0.1	2.0±0.2	4.0±1.0	φ13±0.5	φ60±1	φ180±1

## Packaging specifications

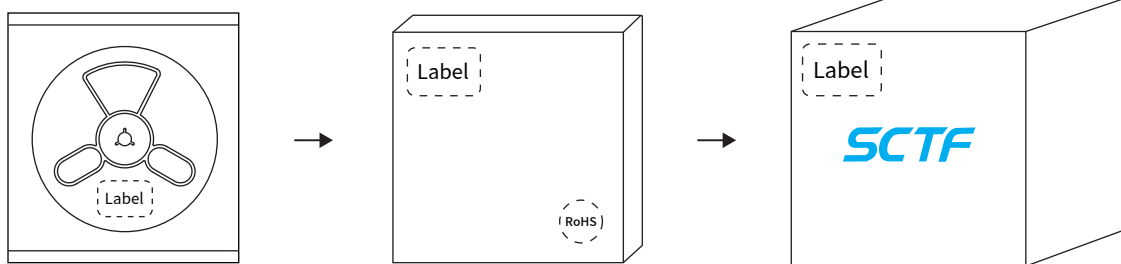

■ 1 reel/box

■ 10 box/carton

Series	Packaging
2CN	3,000 pcs/reel
3CN	3,000 pcs/reel
5CN	1,000 pcs/reel
7CN	1,000 pcs/reel